

Benefits of Digitalization for Business Processes in Semiconductor Manufacturing

Germar Schneider
Infineon Technologies Dresden GmbH
& Co. KG
Dresden, Germany
germar.schneider@infineon.com

Sophia Keil
Faculty of Business Administration and
Engineering
Zittau/Görlitz University of Applied
Sciences
Zittau, Germany
sophia.keil@hszg.de

Fabian Lindner
Faculty of Business Administration and
Engineering
Zittau/Görlitz University of Applied
Sciences
Zittau, Germany
0000-0001-8249-534X

Abstract—The global semiconductor industry is increasingly transforming manufacturing to highly automated and digitized processes. Various novel technologies based on the Internet of Things (IoT) that allow competitive advantages in the European industry emerged thanks to the advancements of digitization and its possibilities supporting the development processes within the semiconductor industry. Digitization, virtualization, digital twins and simulation applications offer the opportunity to create a smart fabrication facility. In this paper, three use cases applying new digitization technologies at the semiconductor front-end facility of Infineon Technologies Dresden supporting the digital transformation in important business processes of the factory are presented. The wafer facilities are already highly automated with respect to the material flows using hundreds of robotics, so that digitization is the next consequent step to improve the performance of the business and speed up processes within the company, especially with the help of digital twins. Besides fabrication automation using only simple robotics for tool loading and unloading, digitization of repetitive, administrative processes implies very high potentials to enhance the competitiveness of a fabrication facility or even a whole fabrication network, not only technically but also in terms of human factors.

Keywords—digitization, digital twin, blockchain, virtual fabrication facility

I. INTRODUCTION

The global industry has changed dramatically in recent years, especially with regard to automation and digitization. Nowadays, the semiconductor industry faces high pressure concerning the costs and time to market. Therefore, the companies have to ensure that products can be delivered with the best cost of ownership, best delivery times and highest quality to the customer. Apart from this, fast changes and short product life cycles of sometimes less than two years from the idea to the volume production increase the pressure regarding fast ramp-ups and time to market.

Digitization and innovative technologies make a major contribution to successfully facing these demands of the market by increasing the competitiveness and productivity of the integrated circuits (IC) suppliers. Therefore, a disruptive step towards speeding up the time to market initializing a “breakthrough change” will be achieved by developing and

implementing a digitalization strategy for the entire European electronic components and systems (ECS) supply chain, closely interlinking development processes, logistics and production.

Major semiconductor companies, including Infineon, are running more than one production fabrication facility in a worldwide fabrication network. Infineon has already gained a lot of experience in fabrication automation, high product mix manufacturing and digitization of business processes [1–8].

Digitization offers the opportunity to link and virtualize all factories as one virtual fabrication facility. A horizontal and vertical integration connecting all processes leads to the creation of a smart fabrication network. New sensors, artificial intelligence and machine learning, support the way towards a smart fabrication network and will cover the particular demands of technology and production [9–14]. Furthermore, one of the main goals of this work is the automation and virtualization and developing and implementing these concepts in different environments by defining innovative digitization strategies. One idea is the automation of cross-factory decision-making and automation of administrative processes for production support to automate repetitive activities, which implicates digital workplaces and smart collaboration as well as smart knowledge management.

More specifically, automation, digitization, and transparent data structures allow establishing digital twins in production. The digital twin leads to digital transformation and will be used to support the automation of administrative processes. A digital twin is a cyber-physical system where data, equipment, or processes are available in the real world and the digital world. It allows replicating a whole production plant, equipment, or a tool in a digital model. Therefore, every digital twin has its physical twin linked with a unique key [15]. This offers the possibility to perform different tests, simulations, and scenarios within the digital model before using it in the real world. Such scenarios could involve improving existing processes, changing processes, or introducing entirely new processes. Due to this fact, a continuous prediction of upcoming statuses is possible, allowing predictive maintenance applications, like e.g. in [15]. Thus, the efficiency concerning time, speed, and costs will be increased due to the verification and test before implementing the physical world [16–17]. Fig. 1 gives a general example of a digital twin. It shows a schematic representation of equipment from the semiconductor industry as a digital model and real object.

As a next step to achieve higher efficiency within a company, repetitive and administrative processes will be

This research was supported by the EU project iDev40. The project iDev40 has received funding from the ECSEL Joint Undertaking (JU) under grant agreement No. 783163. The JU receives support from the European Union’s Horizon 2020 research and innovation program. It is co-funded by the consortium members, as well as grants from Austria, Germany, Belgium, Italy, Spain, and Romania. The content of this article does not reflect the official opinion of the Joint Undertaking ECSEL. The responsibility for the information and views expressed in the article lies entirely with the authors.

automated, especially in different manufacturing departments and with regard to bridging gaps in communication and data between different manufacturing areas. Any automation project starts with typical automation targets like processes with low complexity and a high frequency, so-called repetitive tasks [8]. The main characteristics of repetitive processes can be constituted by the fact that the same sequence of activities, usually defined in detail, is repeatedly passed through. On the other hand, innovative processes are less standardized, and there is a chance for decision-making in defining the sequence of activities, procedures, and tools.

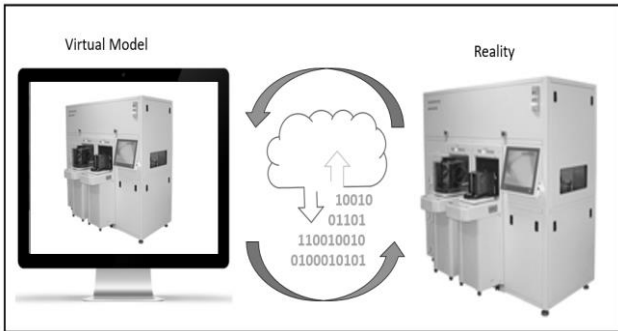

Fig. 1. Schematic example of a digital twin of semiconductor equipment.

Eliminating or reducing repetitive tasks formerly executed by human workers allows them to focus on other and/or more value-adding tasks like, e.g., innovative problem-solving tasks. Furthermore, the employees' stress and frustration levels are reduced due to fewer concentration and cognitive workloads. Instead of this, the worker is allowed to tackle tasks with a higher scope of action, contributing to their well-being at the workplace.

II. STRUCTURE

The paper presents the following three prominent use cases addressing business processes of a wafer facility by explaining how the processes can be made less time-consuming and which further benefits will emerge for semiconductor front-end production with the help of digital twins:

- Use Case 1: Digital twin for wafer start planning
- Use Case 2: Digital twin for wafer dispositioning within the internal fabrication facility supply chains
- Use Case 3: Blockchain as a digital twin of manufacturing steps

The challenging and explicitly selected use cases focus on digitizing Industry 4.0 or industrial internet-based electronic components and systems (ECS) production. They will help take a major step towards a hands-on approach to digitizing the development and manufacturing processes.

The presentation of these three use cases shows the possibilities and advantages of digitization, especially the implementation of digital twins within the semiconductor industry. Notably, there are technical and economic benefits and benefits in terms of the human factors described.

III. USE CASES

A. Digital Twin for Wafer Start Planning

Due to a high automation level within production, the next step leads to administrative processes automation. Digitization captures the possibilities of interlinking databases

to control administrative processes by implementing new workflows or algorithms. It allows the engineers to overcome media disruptions and to speed up processes. Fig. 2 shows how media disruptions occur in administrative processes. Many different computer steps with software like Excel and phone calls are currently used to execute manual processes.

Through efficient workflow management, including intelligent databases, manual steps can be automated without any disruptions. Therefore, engineers can use the time savings to create new value for the company with their work. Within the wafer start planning processes, e.g., around one day of engineering time could be saved. The wafer start processes, including processes controlling wafer starts out of internal or external die banks, could also be included by the automation of those administrative processes.

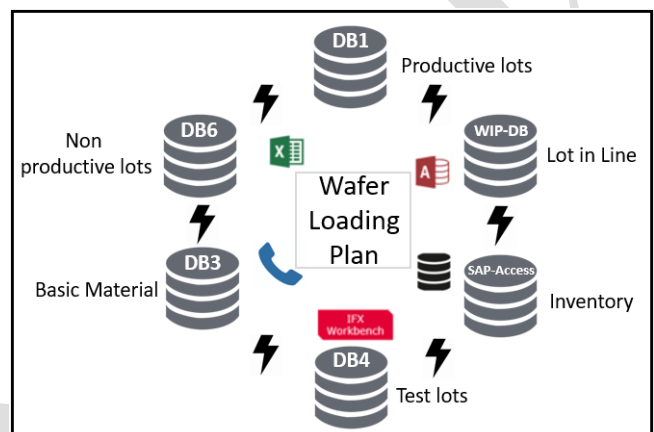

Fig. 2. Media disruptions in the manual processes of the wafer start planning process.

The new approach for the automation of administrative processes includes four main steps: preparation, process mapping, process analysis, and process optimization. Within the second step, Business Process Modelling and Notation (BPMN) was used to map all relevant processes. This model enables a graphical notation of business processes with an execution language, called Business Process Modelling Language (BPML). The main advantage is that the efficiency and transparency of detailed processes can be increased [18]. Fig. 3 gives an exemplary excerpt of the business process modeling approach.

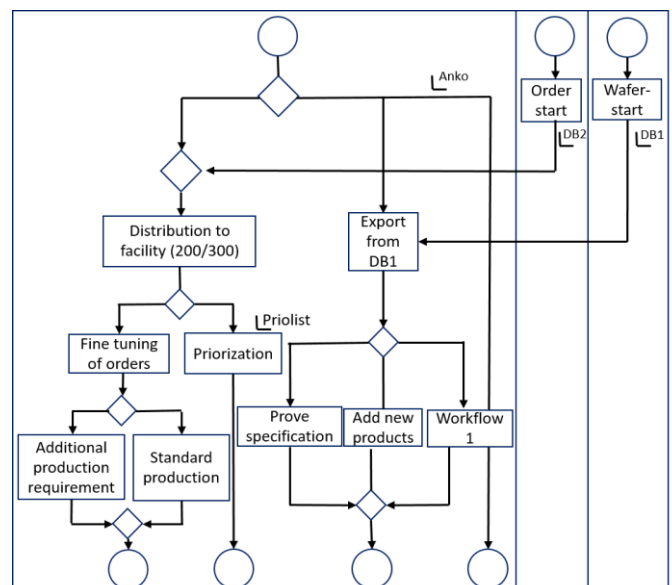

Fig. 3. New approach of process mapping by using BPMN.

Due to the new approach, an automation capability is created for repetitive as well as innovative processes. This new approach allows to use semi-structured and tacit knowledge, and it enables the automation of decision-making processes. Tacit knowledge (as opposed to formal, codified or explicit knowledge) can be defined as skills, ideas, and experiences that employees have in their minds. Therefore, this tacit knowledge is difficult to access. It is often not organized and may not be easily expressed [19]. Fig. 4 illustrates a comparison between the current and modified workflow within the wafer start process, including every detailed step. The modified workflow contains many automated processes and time savings with an amount of over five hours could be achieved. Approximately 70% of manual process steps can be automated by implementing automated systems and the other 30% by intelligent databases. The time savings of every step within the wafer start process are shown in Fig. 5. The main advantage of the modified workflow is the saving of resources and the standardization of the processes.

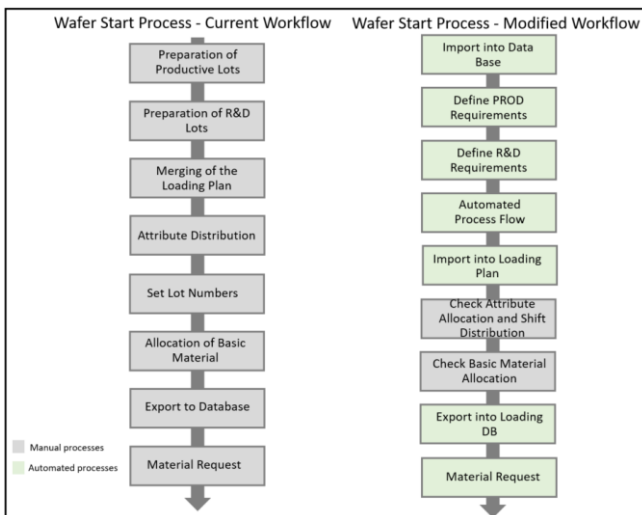

Fig. 4. Representation of current and modified workflow with automated processes.

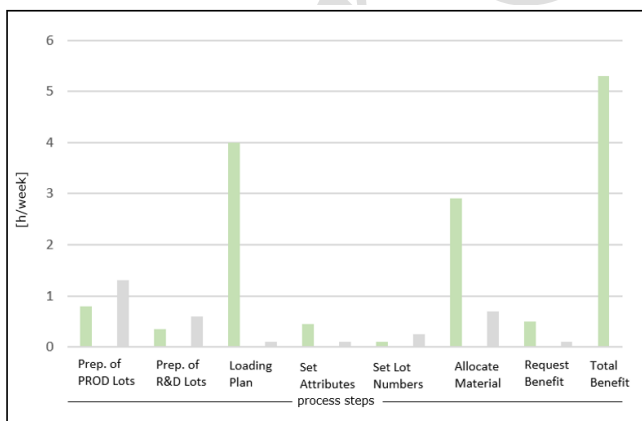

Fig. 5. Improvement potential of the modified process.

Fig. 6 demonstrates the target state where all databases are connected with a continuous workflow controlled by the employees. This process was implemented within one of the first front-end fabrication facilities of Infineon and the goal is to transfer these processes to the other fabrication facilities within the whole production network.

In terms of human factors, the elimination of manual, repetitive, information- and data-intensive tasks using different media and tools adds to the responsible employee's well-being. The employee's high focus requirements due to the importance of the information and data handled are reduced, as well as the probability of mistakes due to manual operations. Overall, the psychological strain of the responsible employee and the level of monotone work are lowered.

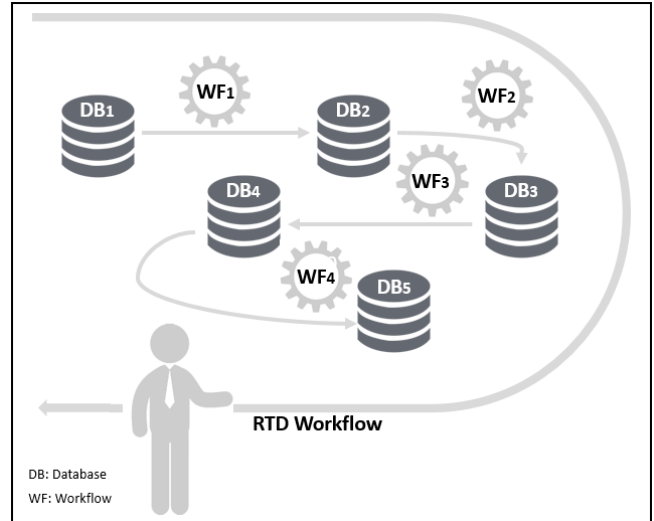

Fig. 6. Automated workflow for real-time dispatching (RTD) based on the digital twin.

B. Digital Twin for Wafer Dispositioning within the Internal Fabrication Facility Supply Chains

The digital twin concept can be used to simplify production planning in a high-mix, high-volume environment. All products require customized flows through different wafer facilities in semiconductor manufacturing, the internal fabrication supply chains. The goal is to optimize the equipment in all facilities at different stages of the manufacturing process. Planning efficient production under these highly flexible circumstances is a complex task that currently requires close communication of engineers capable of making the best decisions possible based on their experience with semiconductor manufacturing and the peculiarities of the respective wafer fabrication facility.

The automated planning states which wafers or lots shall be released into production at which day and time. Fig. 7 shows how an automated optimizer based on the data and information available thanks to the digital twin will coordinate different flows in the fabrication facility to form the lot release plan. The optimizer will eliminate the need for manual communication and human-made decisions and arrange the plan to fully consider fabrication capacities, work in process (WIP) levels and similar indicators at a level of complexity the human brain cannot fully process.

Ideally, the wafer dispositioning optimally fills the fabrication facility's capacity in a balanced manner so that the facility does not need to adapt to different volumes every day. However, in reality, the lot release plan usually varies every day (see Fig. 8). A better but rare example is the lot release schedule in Fig. 9. Automated planning through the optimizer mentioned before can optimize and balance the order release even further.

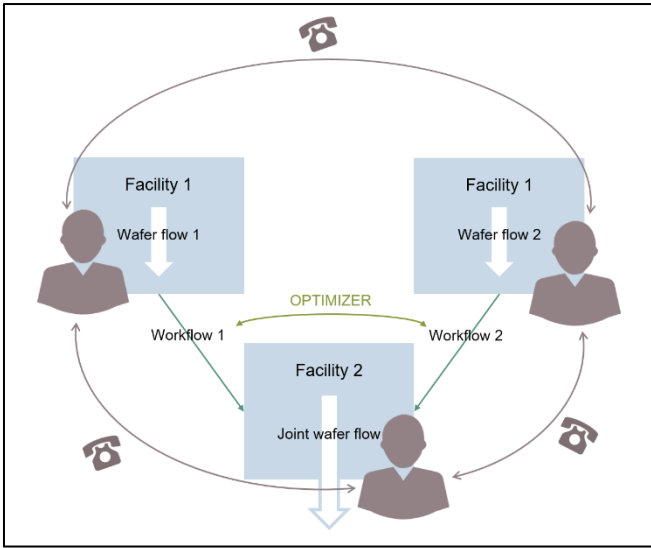

Fig. 7. Optimized production planning of different wafer flows through an optimizer in the digital twin.

Implementing an optimizer will free up the working hours of engineers and improve the wafer facility's efficiency and productivity by planning with more attention to detail. Lot release planning no longer depends on the experience and the current mental condition of a human person.

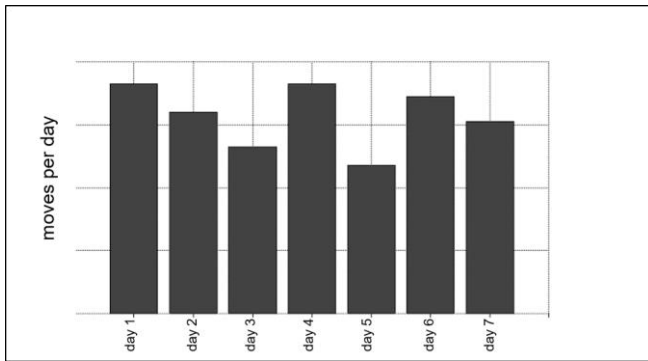

Fig. 8. Irregular order releases into the fabrication facility.

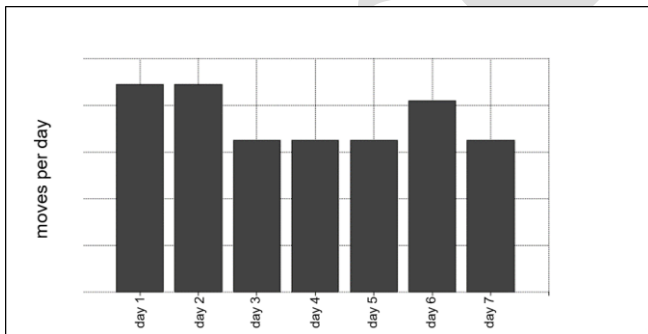

Fig. 9. More regular order releases into the fabrication facility.

C. Blockchain as a Digital Twin of Manufacturing Steps

Another time-consuming process is collecting production data from different data sources and correctly interpreting

them, e.g. concerning possible future scenarios like upcoming WIP waves. In semiconductor manufacturing, the production process consists of different facilities with different functions. Some of these facilities are entirely independent of the rest of the production process, e.g. wafer test and (pre-)assembly, or highly specialized, like galvanic processes, and therefore are often outsourced. Blockchain technology could help ensure data security, data completeness, and data correctness in this decentralized environment.

While currently, the collection of this production data is done by exchanging a myriad of Excel sheets, manual communication, and relying on the honesty and goodwill of the supplier, blockchain guarantees to provide a complete and authentic history of all transactions that were completed on a specific wafer or lot in the respective facility. The basic architecture of a blockchain is shown in Fig. 10. Several transactions – or changes in the dataset – form a block. The information in the block is encrypted through a hashing algorithm that turns a set of input data into an alphanumeric string called a hash. The hash number of the previous block (“parent block”) is calculated into the new block's hash. This way, the blocks are chained together. If the data in one of the previous blocks are manipulated, an error occurs in the chain and the manipulation cannot be completed. Thus, the history of transactions, also called “ledger”, is guaranteed to be correct [20–26].

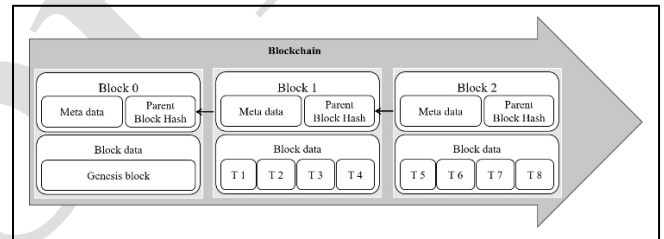

Fig. 10. Blockchain architecture.

Fig. 11 demonstrates how a blockchain works and is embedded into an existing IT infrastructure using the open-source framework Hyperledger Fabric. Before a transaction can be added to the blockchain ledger, it must be validated by a specific group of peers (virtual nodes in the blockchain network that store identical copies of the ledger). All computations (the validation of transactions, running smart contracts, updating the ledger, etc.) occur within the Hyperledger Fabric network.

The end-user (whether it is a machine or a person) is connected to this network of peers by a decentralized app, which writes the smart contract's input line. A smart contract is essentially an automated business scenario that allows a machine to act autonomously within the user organization's rules and therefore represents the automation potential of blockchain. Fig. 12 shows a simplified smart contract for a data query (lines 3–5) and a new transaction (lines 7–33).

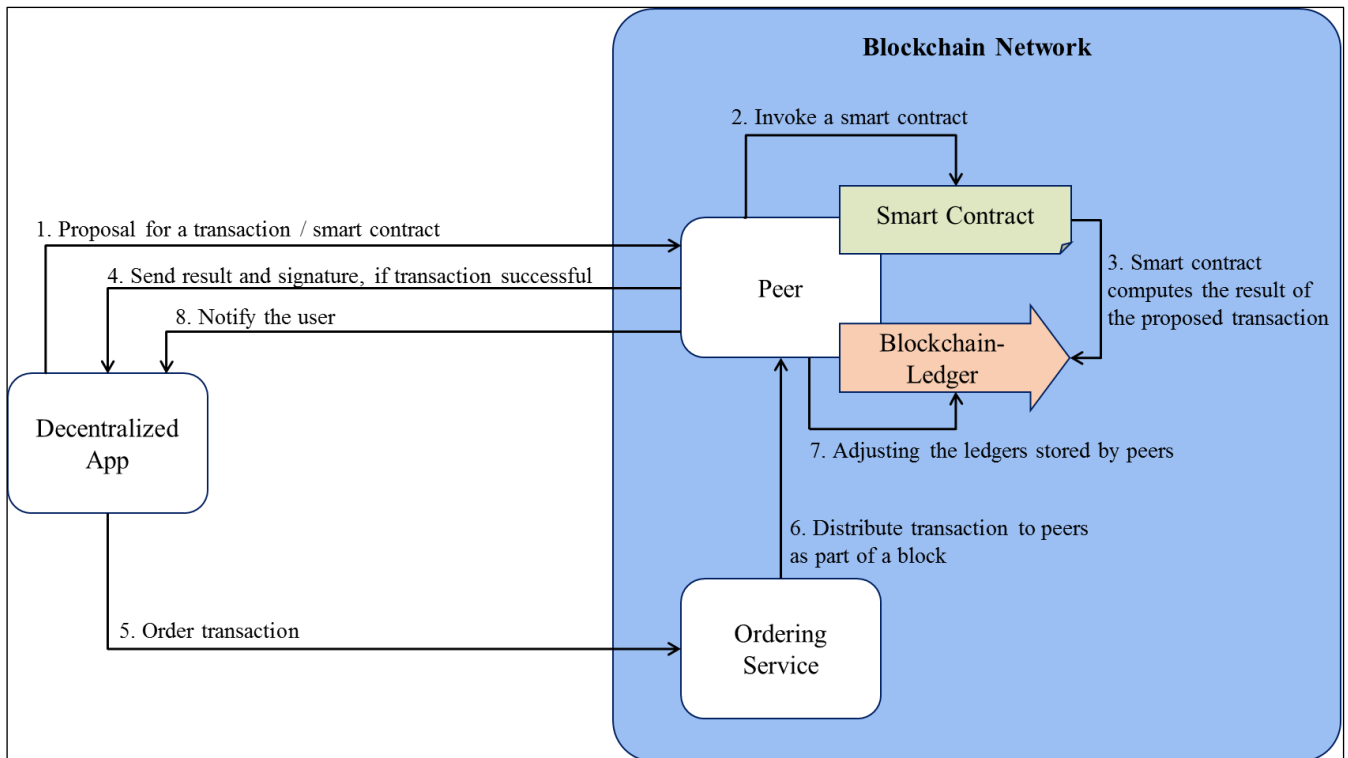

Fig. 11. Transaction flow in the Hyperledger Fabric framework [27].

```

1  lot contract:
2
3  query (lot):
4    get (lot);
5    return lot;
6
7  update (lot, Operation, TransactionType, Owner, ProcessGroup, ProcessClass,
8    BasicType, Customer, TimeStamp, CycleTime, Equipment, Facility, Location,
9    Area, UPT, EPA, Product, InputInUnit1, InputInUnit2, OutputInUnit1,
10   OutputInUnit2, Unit1, Unit2, Route):
11    get (lot);
12    lot.operation = Operation;
13    lot.transaction = TransactionType;
14    lot.owner = Owner;
15    ...
16
17  ...
18
19  31  lot.route = Route;
20  32  put (lot);
21  33  return lot;

```

Fig. 12. Smart contract for a lot history blockchain [27].

A qualitative evaluation of the economic value of this blockchain concept in the semiconductor industry shows that blockchain enables safe interaction within supply chains and standardized data collection in a decentralized production network, and opens up new opportunities regarding the competitive semiconductor market. Fig. 13 stresses those aspects in which blockchain shows significant advantages in the three categories examined: technical, economical, and organizational. Overall, the analytic hierarchy process used for the evaluation showed a goal fulfillment rate of 74% for blockchain compared to 26% for the centralized data warehouse.

In addition to the technical benefits, it is also worth mentioning that the application of a blockchain significantly improves the staff's working conditions. The employee is no longer required to complete the strenuous task of manually collecting data from different sources and no longer needs to communicate with too many entities in the production network or argue about specific pieces of data's correctness. This frees up engineering time for more value-adding tasks, making the work less stressful and more fulfilling.

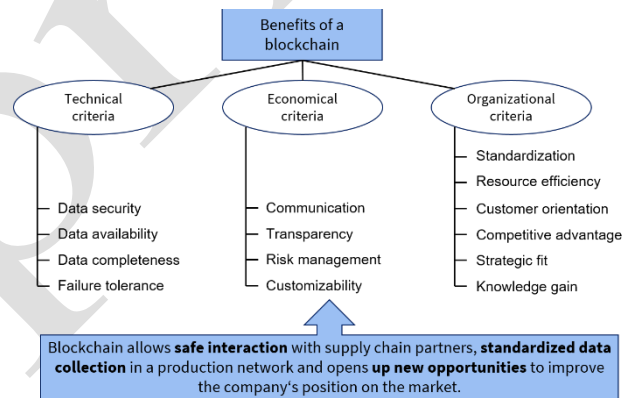

Fig. 13. Benefits of blockchain compared to conventional data storage technologies [27].

This concept can also be transferred to different types of data, like production costs. If cost components were tracked via the blockchain, automatic pay-per-use functionalities can significantly support finance staff. Extending the blockchain to a broader production network will further exploit the benefits. Many more use cases for blockchain have yet to be discovered for the semiconductor industry.

IV. SUMMARY

The demonstrated use cases give an overview of digitization's advantages, especially in terms of creating digital twins. The digital twins provide a virtual representation of the fabrication facility's current status, thus representing an ideal base for various automation projects. Business processes that require engineers to manually collect data from different sources and interpret the data based on their experience can significantly benefit from this new and holistic data representation. Thanks to the digital integration of all process steps, they are no longer required to make phone calls for collecting information, copy and paste data from different tables, and communicate decisions back to the manufacturing

shop floor by speech. These aspects enable the company to remain competitive in the global market of semiconductors. Products can be offered with a lower total cost of ownership, shorter time to market, and highest quality to achieve greater customer satisfaction. Besides technical factors, human workers are essential for the success of digital twins as well, as they must understand and master the technologies at any time. Therefore, people should be at the center of digitization to ensure the control and use of these technologies. This implies, among others, new organizational structures, management support throughout the implementation, training, a culture of mutual feedback, collaboration and respective governance structures, and intercultural competencies to empower globally distributed development teams to benefit from the new possibilities of the digital twins optimally.

ACKNOWLEDGMENT

Special thanks to Laura Herrgoß for her work on blockchain applications as part of her thesis and Jacob Lohmer and Rainer Lasch from the Technische Universität Dresden for supervising her work.

REFERENCES

- [1] S. Keil, F. Lindner, T. Jakubowitz, and G. Schneider, "A planning approach for an effective digitalization of processes in mature semiconductor production facilities," 2019 30th Annu. SEMI Adv. Semicond. Manuf. Conf., Saratoga Springs, NY, USA, 2019, pp. 1–6.
- [2] G. Schneider, S. Keil, and G. Luhn, "Opportunities, challenges and use cases of digitization within the semiconductor industry," 2018 29th Annu. SEMI Adv. Semicond. Manuf. Conf., Saratoga Springs, NY, USA, 2018, pp. 307–312.
- [3] S. Keil, G. Schneider, and H. Heinrich, "Enhancing flexibility and robustness of semiconductor production by using autonomous modular services," 2018 29th Annu. SEMI Adv. Semicond. Manuf. Conf., Saratoga Springs, NY, USA, 2018, pp. 359–364.
- [4] G. Schneider, T. Wagner, and M. Kraft, "Use of simulation studies to overcome key challenges in the fab automation of a 300 mm power semiconductor pilot line comprising thin-wafer processing," 2015 26th Annu. SEMI Adv. Semicond. Manuf. Conf., Saratoga Springs, NY, USA, 2015, pp. 42–47.
- [5] S. Rank, C. Hammel, G. Schneider, and T. Schmidt, "Reducing simulation model complexity by using an adjustable base model for path-based system: a case study in the semiconductor industry," 2015 Winter Simul. Conf., Huntington Beach, CA, USA, 2015, pp. 2896–2907.
- [6] T. Wagner, C. Schwenke, K. Kabitzsch, and G. Schneider, "Automated planning, execution and evaluation of simulation experiments of semiconductor AMHS," 2013 Winter Simul. Conf., Washington, D.C., USA, 2013, pp. 3891–3904.
- [7] S. Keil, D. Eberts, R. Lasch, and G. Schneider, "Managing variability within wafer test production by combining Lean and Six Sigma," 2012 SEMI Adv. Semicond. Manuf. Conf., Saratoga Springs, NY, USA, 2012, pp. 33–38.
- [8] H. Heinrich, S. Keil, G. Schneider, F. Heinlein, R. Lasch, and A. Deutschländer, "Pursuing the increase of factory automation in 200mm frontend manufacturing to manage the changes imposed by the transition from high-volume low-mix to high-mix low-volume production," 2008 IEEE/SEMI Adv. Semicond. Manuf. Conf., Cambridge, MA, USA, 2008, pp. 148–155.
- [9] G. Soós, D. Ficzer, and P. Varga, "On power utilization of IoT devices connected to NB-IoT cellular access networks," unpublished.
- [10] D. Kozma, G. Soós, and P. Varga, "Supporting LTE network and service management through session data record analysis," *Infocommun. J.*, vol. VIII, no. 2, pp. 11–16, June 2016.
- [11] D. Kozma, G. Soós, D. Ficzer, and P. Varga, "Communication challenges and solutions between heterogeneous Industrial IoT systems," 2019 15th Int. Conf. Netw. Serv. Manag., Halifax, NS, Canada, 2019, pp. 1–6.
- [12] C. Hegedűs, D. Kozma, G. Soós, and P. Varga, "Enhancements of the Arrowhead Framework to refine inter-cloud service interactions," 42nd Annu. Conf. IEEE Ind. Electron. Soc., Florence, Italy, 2016, pp. 5259–5264.
- [13] D. Kozma, P. Varga, and G. Soós, "Supporting digital production, product lifecycle and supply chain management in Industry 4.0 by the Arrowhead Framework – a survey," 2019 IEEE 17th Int. Conf. Ind. Inform., Helsinki, Finland, 2019, pp. 126–131.
- [14] D. Kozma, P. Varga, and F. Larrinaga, "Data-driven workflow management by utilising BPMN and CPN in IIoT systems with the Arrowhead Framework," 2019 24th IEEE Int. Conf. Emerg. Technol. Fact. Autom., Zaragoza, Spain, 2019, pp. 385–392.
- [15] J. Ríos, J. Hernández, M. Oliva, and F. Mas, "Product avatar as digital counterpart of a physical individual product: literature review and implications in an aircraft," 22nd ISPE Inc. Int. Conf. Concurr. Eng., Delft, the Netherlands, 2015, pp. 657–666.
- [16] L. Wang and G. Wang, "Big Data in Cyber-Physical Systems, digital manufacturing and Industry 4.0," *Int. J. Eng. Manuf.*, vol. 6, no. 4, pp. 1–8, 2016.
- [17] A. T. Al-Hammouri, "A comprehensive co-simulation platform for cyber-physical systems," *Comput. Commun.*, vol. 36, no. 1, pp. 8–19, December 2012.
- [18] B. List and B. Korherr, "An evaluation of conceptual business process modelling languages," 2006 ACM Symp. Appl. Comput., Dijon, France, 2006, pp. 1532–1539.
- [19] R. Chugh, "Do Australian universities encourage tacit knowledge transfer?" 7th Int. Jt. Conf. Conf. Knowl. Discov. Knowl. Eng. Know. Manag., Lisbon, Portugal, 2015, pp. 128–135.
- [20] M. Y. Afanasev, Y. V. Fedosov, A. A. Krylova, and S. A. Shorokhov, "An application of blockchain and smart contracts for machine-to-machine communications in cyber-physical production systems," 2018 IEEE Ind. Cyber-Phys. Syst., St. Petersburg, Russia, 2018, pp. 13–19.
- [21] A. Angrish, B. Craver, M. Hasan, and B. Starly, "A case study for Blockchain in manufacturing: 'fabRec': a prototype for peer-to-peer network of manufacturing nodes," *Procedia Manuf.*, vol. 26, pp. 1180–1192, 2018.
- [22] A. V. Barenji, Z. Li, and W. M. Wang, "Blockchain cloud manufacturing: shop floor and machine level," *Smart SysTech 2018 European Conf. Smart Objects Syst. Technol.*, Munich, Germany, 2018, pp. 1–6.
- [23] M. Isaja and J. Soldatos, "Distributed ledger technology for decentralization of manufacturing processes," 2018 IEEE Ind. Cyber-Phys. Syst., St. Petersburg, Russia, 2018, pp. 696–701.
- [24] J. A. Jimenez, A. Ramasubramanian, and G. Psimenos, "IoT based Blockchain for manufacturing process monitoring and logistics within an organisation", <http://ajulio.com/assets/documents/Blockchain.pdf> (accessed January 22, 2021).
- [25] T. Kobzan, A. Biendarra, S. Schriegel, T. Herbst, T. Müller, and J. Jasperneite, "Utilizing Blockchain technology in industrial manufacturing with the help of network simulation," *IEEE 16th Int. Conf. Ind. Inform.*, Porto, Portugal, 2018, pp. 152–159.
- [26] S. Nakamoto, "Bitcoin: a peer-to-peer electronic cash system," October 2008.
- [27] L. Herrgoß, J. Lohmer, G. Schneider, and R. Lasch, "Development and evaluation of a Blockchain concept for production planning and control in the semiconductor industry," 2020 IEEE Int. Conf. Ind. Eng. Eng. Manag., Singapore, 2020, pp. 440–444.